

DOOR CONTACT EDC SERIES

Features

- For use in controlling the closure position of lift doors or as switch for locking mechanism of automatic doors safety switch with positive contact
- Quiet Functioning
- Self-cleaning double break contact for long service life

Specifications

Enclosure Material	Fiber reinforced PA6/66 (UL94-V0)
Cover Material	Polycarbonate (UL94-V0) transparent
Actuator	Silver-plated brass with PA6/66 (UL94-V0) enclosure
Contact Material	Cu-rivets with silver coating
Mounting	2xM4 thread rolling captive screws
Contact Type	1NC
Termination	M3.5 screw switch self-lifting clamp (conductor cross-section 0.5 to 1.5 mm ²)
Switching Frequency	30 ops/min
Rated Thermal Current (I _{th})	4A
Rated Operation Current/Voltage (I _e /U _e)	2A/230VAC; 2A/200VDC (according to EN81-1, -2)
Short-time current protective device	Fuse 6A gL
Ambient Temperature	-30~+80°C (-22~176°F)
Mechanical Life	Mechanically 10 millions operations
Degree of Protection	IP20 to IEC/EN60529
Standards	EN81, CAN/CSA-B44.1/ASME-A15.5, VDE 0660

EDC-51

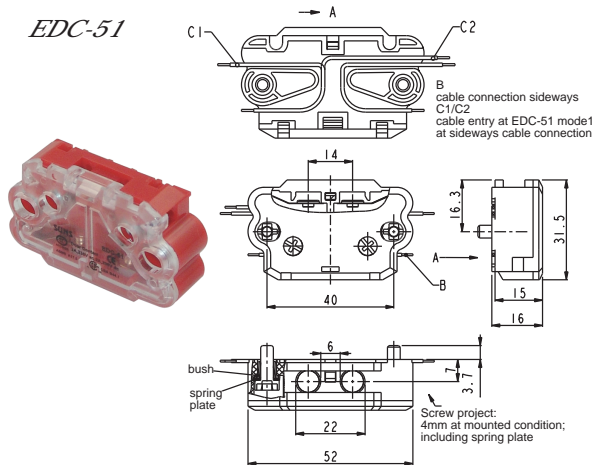

EDC-52

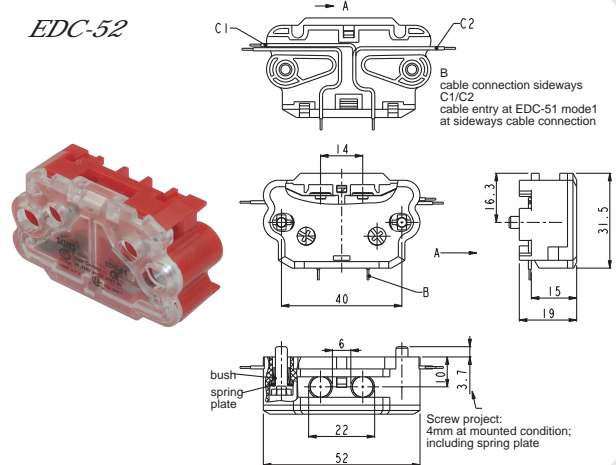

EDC-61

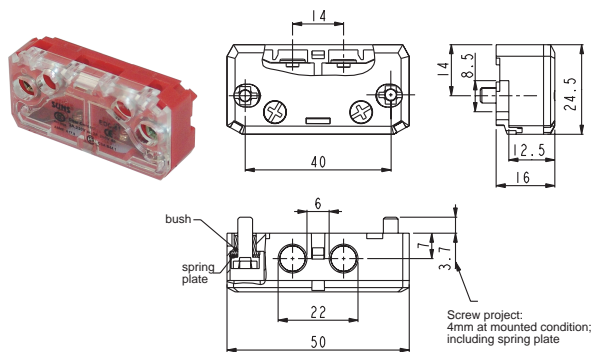

EDC-62

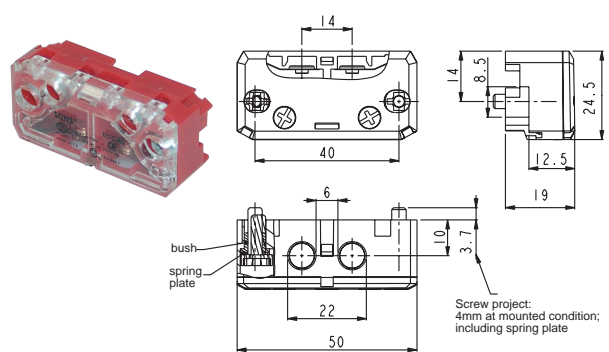

DOOR CONTACT EDC SERIES

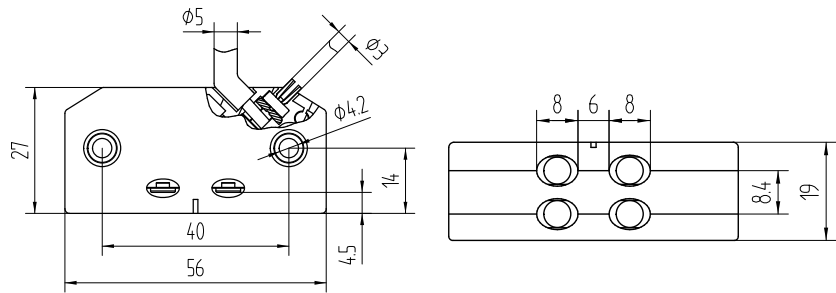

EDC-63

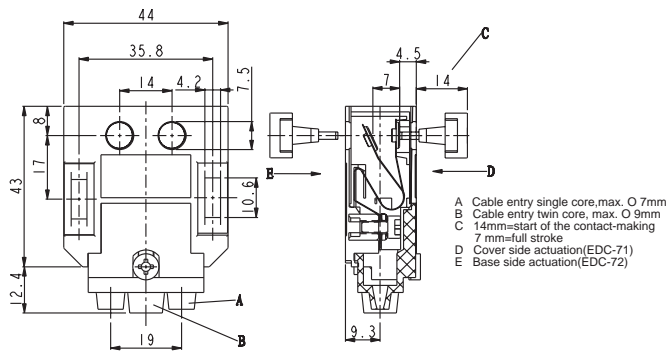

EDC-71 EDC-72

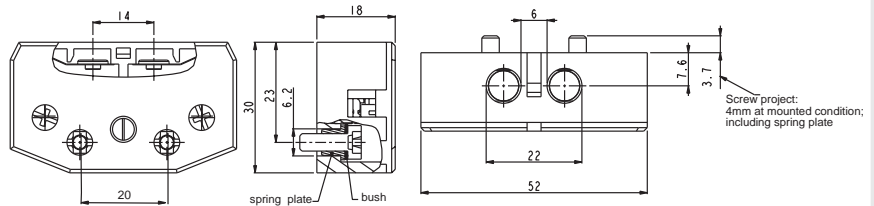

EDC-8

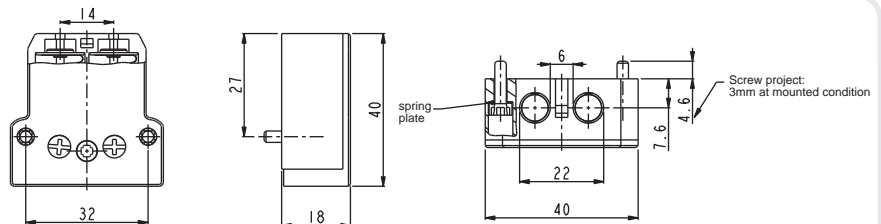

EDC-92

DCA ACTUATOR FOR DOOR CONTACT

For use with EDC5,EDC6,EDC7,EDC8,EDC9 door contacts

DCA-18 DCA-21 DCA-24

DCA-S

DCA-F

DCA-F2

DCA-F3

DCA-18T

DCA-18TB