

FSBM-1 Series Medical Foot Switches

Features

- Zinc die cast base
- Compact size
- Ergonomic low profile design
- Easy to clean
- High mechanical stability
- Soft touch button with light operating force

Specifications

Operating Frequency	60 ops/min
Insulation Resistance	>100MΩ@500V DC
Contact Resistance	<25mΩ (initial)
Rated Current/Voltage	5A or 10A 0-250V
Dielectric Strength	1000VAC for 1 min between current carrying parts 2500VAC for 1 min between non-current carrying parts
Service Life	1 x 10 ⁶ (operations)
Operating Temperature	20~+80°C (-4~176°F)
Degree of Protection	IP68 (NEMA 4, 4x, 6, 6P)

Selection Guide:

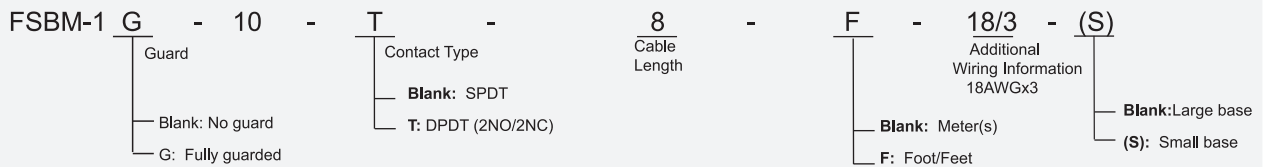

Dimensions:

FSBM-1-10-2-18/3 (18AWGx3, 2 meters, 1x 1NO)

FSBM-1-10-T-2-20/4S (20AWGx4, shielded, 2 meters, 2NO/2NC, cable diameter 7.0mm)

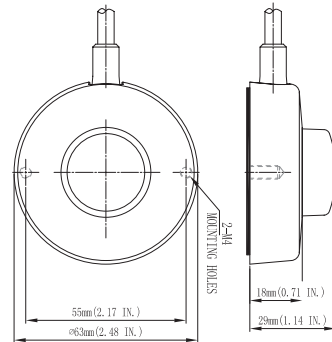

FSBM-1-10-2-18/3(80) (18AWGx3, 2 meters, 1x 1NO)

FSBM-1-10-T-2-22/5S(80) (22AWGx5, shielded, 2 meters, 2NO/2NC, cable diameter 5.6mm)

